



[Http://www.dqstar.com](http://www.dqstar.com)

**Axial ac
fan**

交流风机

DEQING

STAR ELECTRONIC CO.,LTD.

**Axial dc
fan**

直流风机

FM 8025/FM8038 Axial ac fan

交流风机



Unit in mm

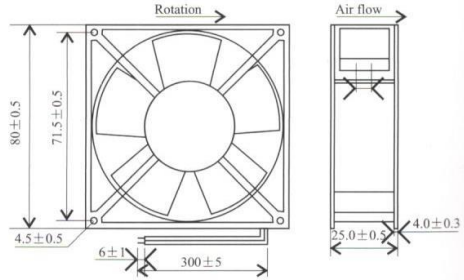

80 × 80 × 25mm(Square)

型号 Model	频率 Frequency Hz	电压 Voltage V	轴承 Bearing Type	电流 Current Amp	功率 Power W	转速 Speed Rpm	风量 Airflow Cfm	噪音 Noise dB(A)	重量 Weight Gram
FM8025A1HSL	50/60	110	Sleeve	0.13/0.12	13/12	2450	16/18	28/29	230g
FM8025A1HBL	50/60	110	Ball	0.13/0.12	13/12	2450	16/18	28/29	
FM8025A2HSL	50/60	220	Sleeve	0.08/0.07	13/12	2450	16/18	28/29	
FM8025A2HBL	50/60	220	Ball	0.08/0.07	13/12	2450	16/18	28/29	
FM8025A1/A2HSL	50/60	110/220	Sleeve	0.13/0.08	13/12	2450	16/18	28/29	
FM8025A1/A2HBL	50/60	110/220	Ball	0.13/0.08	13/12	2450	16/18	28/29	

FM=Factory Model , 8025=80*80*25mm ,A1=AC 110V , A2=AC 220V , H=High speed , S=Sleeve , B=Ball , L=Lead wire

AXIAL AC FAN

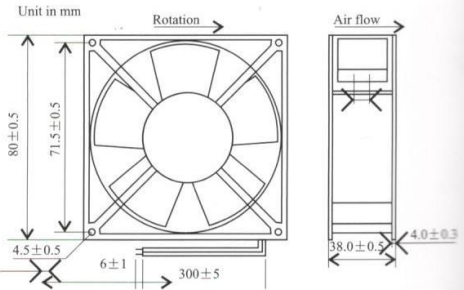

80 × 80 × 38mm(Square)

型号 Model	频率 Frequency Hz	电压 Voltage V	轴承 Bearing Type	电流 Current Amp	功率 Power W	转速 Speed Rpm	风量 Airflow Cfm	噪音 Noise dB(A)	重量 Weight Gram
FM8038A1HSL	50/60	110	Sleeve	0.15/0.13	14/13	2400	26/30	28/31	340g
FM8038A1HBL	50/60	110	Ball	0.15/0.13	14/13	2400	26/30	28/31	
FM8038A2HSL	50/60	220	Sleeve	0.08/0.07	14/13	2400	26/30	28/31	
FM8038A2HBL	50/60	220	Ball	0.08/0.07	14/13	2400	26/30	28/31	
FM8038A1/A2HSL	50/60	110/220	Sleeve	0.15/0.08	14/13	2400	26/30	28/31	
FM8038A1/A2HBL	50/60	110/220	Ball	0.15/0.08	14/13	2400	26/30	28/31	

FM=Factory Model , 8038=80*80*38mm ,A1=AC 110V , A2=AC 220V , H=High speed , S=Sleeve , B=Ball , L=Lead wire

FM 9225/FM9238 Axial ac fan

交流风机

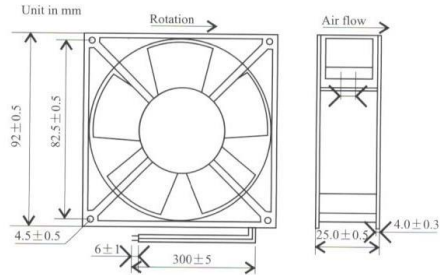

92 × 92 × 25mm(Square)

型号 Model	频率 Frequency Hz	电压 Voltage V	轴承 Bearing Type	电流 Current Amp	功率 Power W	转速 Speed Rpm	风量 Airflow Cfm	噪音 Noise dB(A)	重量 Weight Gram
FM9225A1HSL	50/60	110	Sleeve	0.14/0.12	13/12	2400	28/34	29/33	270g
FM9225A1HBL	50/60	110	Ball	0.14/0.12	13/12	2400	28/34	29/33	
FM9225A2HSL	50/60	220	Sleeve	0.08/0.07	13/12	2400	28/34	29/33	
FM9225A2HBL	50/60	220	Ball	0.08/0.07	13/12	2400	28/34	29/33	
FM9225A1/A2HSL	50/60	110/220	Sleeve	0.14/0.08	13/12	2400	28/34	29/33	
FM9225A1/A2HBL	50/60	110/220	Ball	0.14/0.08	13/12	2400	28/34	29/33	

FM=Factory Model , 9225=92*92*25mm , A1=AC 110V , A2=AC 220V , H=High speed , S=Sleeve , B=Ball , L=Lead wire

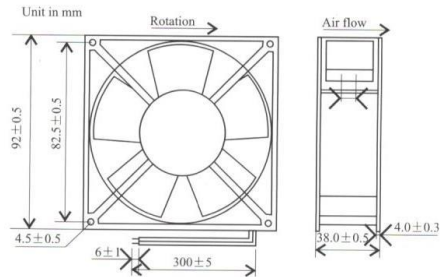

92 × 92 × 38mm(Square)

型号 Model	频率 Frequency Hz	电压 Voltage V	轴承 Bearing Type	电流 Current Amp	功率 Power W	转速 Speed Rpm	风量 Airflow Cfm	噪音 Noise dB(A)	重量 Weight Gram
FM9238A1HSL	50/60	110	Sleeve	0.15/0.13	15/13	2400	50/54	31/36	360g
FM9238A1HBL	50/60	110	Ball	0.15/0.13	15/13	2400	50/54	31/36	
FM9238A2HSL	50/60	220	Sleeve	0.08/0.07	15/13	2400	50/54	31/36	
FM9238A2HBL	50/60	220	Ball	0.08/0.07	15/13	2400	50/54	31/36	
FM9238A1/A2HSL	50/60	110/220	Sleeve	0.15/0.08	15/13	2400	50/54	31/36	
FM9238A1/A2HBL	50/60	110/220	Ball	0.15/0.08	15/13	2400	50/54	31/36	

FM=Factory Model , 9238=92*92*38mm , A1=AC 110V , A2=AC 220V , H=High speed , S=Sleeve , B=Ball , L=Lead wire

AXIAL AC FAN

FM 10826/FM12025 Axial ac fan

交流风机

sunflow

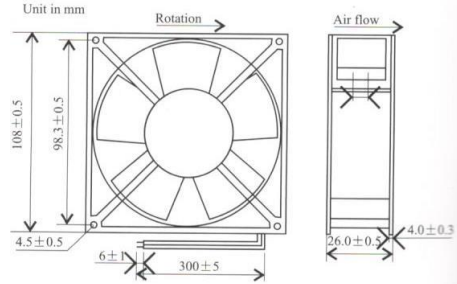

108 × 108 × 26mm(Square)

型号 Model	频率 Frequency Hz	电压 Voltage V	轴承 Bearing Type	电流 Current Amp	功率 Power W	转速 Speed Rpm	风量 Airflow Cfm	噪音 Noise dB(A)	重量 Weight Gram
FM10826A1HSL	50/60	110	Sleeve	0.16/0.14	16/15	2300	40	33/38	330g
FM10826A1HBL	50/60	110	Ball	0.16/0.14	16/15	2300	40	33/38	
FM10826A2HSL	50/60	220	Sleeve	0.08/0.07	16/15	2300	40	33/38	
FM10826A2HBL	50/60	220	Ball	0.08/0.07	16/15	2300	40	33/38	
FM10826A1/A2HSL	50/60	110/220	Sleeve	0.14/0.08	16/15	2300	40	33/38	
FM10826A1/A2HBL	50/60	110/220	Ball	0.14/0.08	16/15	2300	40	33/38	

FM=Factory Model, 10826=108*108*26mm, A1=AC 110V, A2=AC 220V, H=High speed, S=Sleeve, B=Ball, L=Lead wire

AXIAL AC FAN

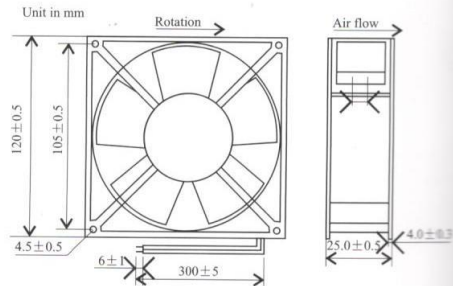

120 × 120 × 25mm(Square)

型号 Model	频率 Frequency Hz	电压 Voltage V	轴承 Bearing Type	电流 Current Amp	功率 Power W	转速 Speed Rpm	风量 Airflow Cfm	噪音 Noise dB(A)	重量 Weight Gram
FM12025A1HSL	50/60	110	Sleeve	0.15/0.14	16/15	2400	51/61	40/41	380g
FM12025A1HBL	50/60	110	Ball	0.15/0.14	16/15	2400	51/61	40/41	
FM12025A2HSL	50/60	220	Sleeve	0.08/0.07	16/15	2400	51/61	40/41	
FM12025A2HBL	50/60	220	Ball	0.08/0.07	16/15	2400	51/61	40/41	
FM12025A1/A2HSL	50/60	110/220	Sleeve	0.14/0.08	16/15	2400	51/61	40/41	
FM12025A1/A2HBL	50/60	110/220	Ball	0.14/0.08	16/15	2400	51/61	40/41	

FM=Factory Model, 12025=120*120*25mm, A1=AC 110V, A2=AC 220V, H=High speed, S=Sleeve, B=Ball, L=Lead wire

FM 12038 Axial ac fan

交流风机

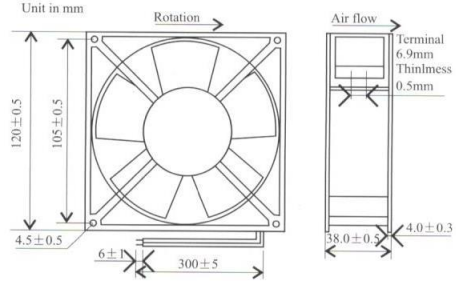

120 × 120 × 38mm(Square)

型号 Model	频率 Frequency Hz	电压 Voltage V	轴承 Bearing Type	电流 Current Amp	功率 Power W	转速 Speed Rpm	风量 Airflow Cfm	噪音 Noise dB(A)	重量 Weight Gram
FM12038A1HSL	50/60	110	Sleeve	0.24/0.23	26/23	2800	90/100	40/45	500g
FM12038A1HBL	50/60	110	Ball	0.24/0.23	26/23	2800	90/100	40/45	
FM12038A2HSL	50/60	220	Sleeve	0.14/0.13	26/23	2700	90/100	40/45	
FM12038A2HBL	50/60	220	Ball	0.14/0.13	26/23	2700	90/100	40/45	
FM12038A3HSL	50/60	380	Sleeve	0.07/0.06	26/23	2700	90/100	40/45	
FM12038A3HBL	50/60	380	Ball	0.07/0.06	26/23	2700	90/100	40/45	
FM12038A1/A2HSL	50/60	110/220	Sleeve	0.23/0.14	26/23	2700	90/100	40/45	
FM12038A1/A2HBL	50/60	110/220	Ball	0.23/0.14	26/23	2700	90/100	40/45	

FM=Factory Model , 12038=120*120*38mm , A1=AC 110V , A2=AC 220V , H=High speed , S=Sleeve , B=Ball , L=Lead wire , T=Terminal

Fan with 7 Blades Type A



Fan with 7 Blades Type B



Fan with Flat Plug



Fan with Round Plug



AXIAL AC FAN

FM 17238/FM17250 Axial ac fan



交流风机

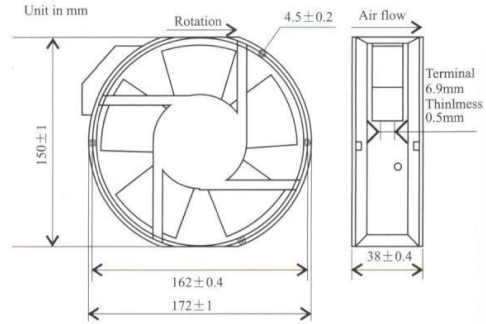

172 × 150 × 38mm(Oval)

AXIAL AC FAN

型号 Model	频率 Frequency Hz	电压 Voltage V	轴承 Bearing Type	电流 Current Amp	功率 Power W	转速 Speed Rpm	风量 Airflow Cfm	噪音 Noise dB(A)	重量 Weight Gram
FM17238A1HSL	50/60	110	Sleeve	0.40/0.35	43/36	2300	150/170	48/51	800g
FM17238A1HBL	50/60	110	Ball	0.40/0.35	43/36	2300	150/170	48/51	
FM17238A2HSL	50/60	220	Sleeve	0.21/0.17	43/36	2300	150/170	48/51	
FM17238A2HBL	50/60	220	Ball	0.21/0.17	43/36	2300	150/170	48/51	

FM=Factory Model, 17238=172*150*38mm ,A1=AC 110V, A2=AC 220V, H=High speed, S=Sleeve, B=Ball, L=Lead wire, T=Terminal

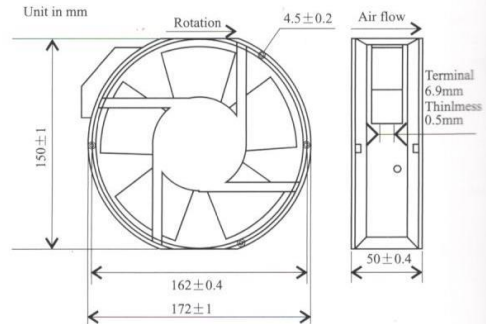
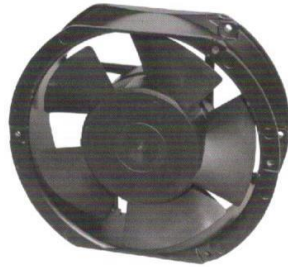

172 × 150 × 50mm(Oval)

型号 Model	频率 Frequency Hz	电压 Voltage V	轴承 Bearing Type	电流 Current Amp	功率 Power W	转速 Speed Rpm	风量 Airflow Cfm	噪音 Noise dB(A)	重量 Weight Gram
FM17250A1HSL	50/60	110	Sleeve	0.47/0.46	37/35	2500	150/170	52/53	950g
FM17250A1HBL	50/60	110	Ball	0.47/0.46	37/35	2500	150/170	52/53	
FM17250A2HSL	50/60	220	Sleeve	0.23/0.22	37/35	2500	150/170	52/53	
FM17250A2HBL	50/60	220	Ball	0.23/0.22	37/35	2500	150/170	52/53	

FM=Factory Model, 17250=172*150*50mm ,A1=AC 110V, A2=AC 220V, H=High speed, S=Sleeve, B=Ball, L=Lead wire, T=Terminal

FM 17251/FM17051 Axial ac fan



交流风机

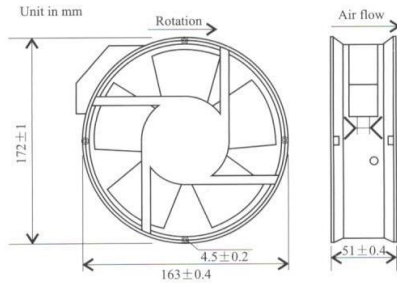

172 × 163 × 51mm(Round)

型号 Model	频率 Frequency Hz	电压 Voltage V	轴承 Bearing Type	电流 Current Amp	功率 Power W	转速 Speed Rpm	风量 Airflow Cfm	噪音 Noise dB(A)	重量 Weight Gram
FM17251A1HSL	50/60	110	Sleeve	0.47/0.46	37/35	2400	150/170	52/53	950g
FM17251A1HBL	50/60	110	Ball	0.47/0.46	37/35	2400	150/170	52/53	
FM17251A2HSL	50/60	220	Sleeve	0.23/0.22	37/35	2400	150/170	52/53	
FM17251A2HBL	50/60	220	Ball	0.23/0.22	37/35	2400	150/170	52/53	

FM=Factory Model , 17251=172*163*51mm ,A1=AC 110V , A2=AC 220V , H=High speed , S=Sleeve , B=Ball , L=Lead wire

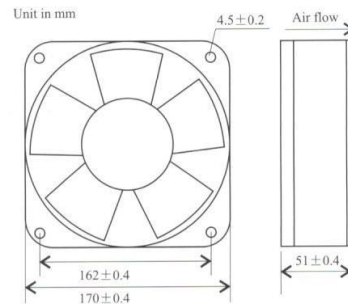

170 × 170 × 51mm(Round & Square)

型号 Model	频率 Frequency Hz	电压 Voltage V	轴承 Bearing Type	电流 Current Amp	功率 Power W	转速 Speed Rpm	风量 Airflow Cfm	噪音 Noise dB(A)	重量 Weight Gram
FM17051A1HSL	50/60	110	Sleeve	0.47/0.46	37/35	2400	150/170	52/53	1000g
FM17051A1HBL	50/60	110	Ball	0.47/0.46	37/35	2400	150/170	52/53	
FM17051A2HSL	50/60	220	Sleeve	0.23/0.22	37/35	2400	150/170	52/53	
FM17051A2HBL	50/60	220	Ball	0.23/0.22	37/35	2400	150/170	52/53	

FM=Factory Model , 17051=170*170*51mm ,A1=AC 110V , A2=AC 220V , H=High speed , S=Sleeve , B=Ball , L=Lead wire

AXIAL AC FAN

FM 15050/150FZY Axial ac fan

交流风机

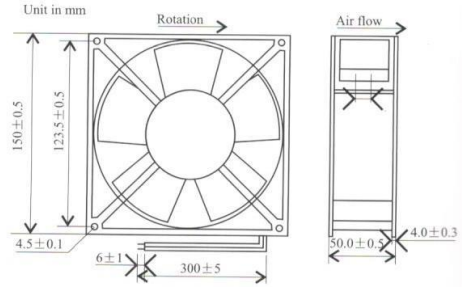

150 × 150 × 50mm(Square)

AXIAL AC FAN

型号 Model	频率 Frequency Hz	电压 Voltage V	轴承 Bearing Type	电流 Current Amp	功率 Power W	转速 Speed Rpm	风量 Airflow Cfm	噪音 Noise dB(A)	重量 Weight Gram
FM15050A1HSL	50/60	110	Sleeve	0.47/0.46	37/35	2700	190/220	52/53	950g
FM15050A1HBL	50/60	110	Ball	0.47/0.46	37/35	2700	190/220	52/53	
FM15050A2HSL	50/60	220	Sleeve	0.23/0.22	37/35	2700	190/220	52/53	
FM15050A2HBL	50/60	220	Ball	0.23/0.22	37/35	2700	190/220	52/53	

FM=Factory Model, 15050=150*150*50mm, A1=AC 110V, A2=AC 220V, H=High speed, S=Sleeve, B=Ball, L=Lead wire

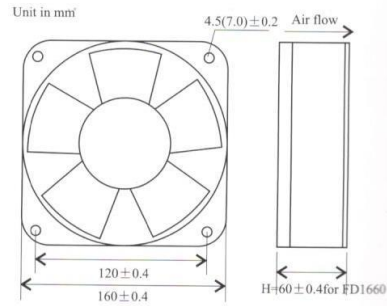

150FZY Series

型号 Model	频率 Frequency Hz	电压 Voltage V	轴承 Bearing Type	电流 Current Amp	功率 Power W	转速 Speed Rpm	风量 Airflow m³/min	噪音 Noise dB(A)	相数 Phase	电容 Capacitor μ F/V
150FZY1-D	50/60	110V	Ball	0.32	30	2500	5.5	65	1	3 μ F/250v
150FZY2-D	50/60	220V	Ball	0.15	30	2500	5.5	65	1	1 μ F/500v
150FZY3-D	50/60	380V	Ball	0.09	30	2500	5.5	65	3	/
150FZY4-D	50/60	380V	Ball	0.10	30	2500	5.5	65	1	0.47 μ F/500v

FM 18060/FM20060R

Axial ac fan



交流风机

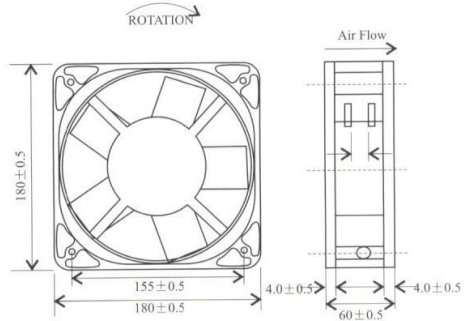

180x180x60mm(Square)

型号 Model	频率 Frequency Hz	电压 Voltage V	轴承 Bearing Type	电流 Current Amp	功率 Power W	转速 Speed Rpm	风量 Airflow Cfm	噪音 Noise dB(A)	重量 Weight Gram
FM18060A1HBL	50/60	110	Ball	0.60	50	2450	260	58	1600g
FM18060A2HBL	50/60	220	Ball	0.35	50	2450	260	58	
FM18060A3HBL	50/60	380	Ball	0.25	50	2450	260	58	

FM=Factory Model , 18060=180*180*60mm , A1=AC 110V , A2=AC 220V , H=High speed , S=Sleeve , B=Ball , L=Lead wire

AXIAL AC FAN

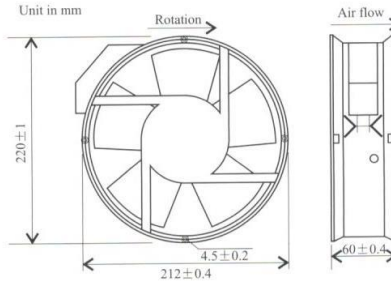

200 × 200 × 60mm(Round)

型号 Model	频率 Frequency Hz	电压 Voltage V	轴承 Bearing Type	电流 Current Amp	功率 Power W	转速 Speed Rpm	风量 Airflow Cfm	噪音 Noise dB(A)	重量 Weight Gram
FM20060A1HSL	50/60	110	Sleeve	0.58/0.50	56/54	2100	170/180	64/66	1700g
FM20060A1HBL	50/60	110	Ball	0.58/0.50	56/54	2100	170/180	64/66	
FM20060A2HSL	50/60	220	Sleeve	0.31/0.30	56/54	2100	170/180	64/66	
FM20060A2HBL	50/60	220	Ball	0.31/0.30	56/54	2100	170/180	64/66	

FM=Factory Model , 20060=200*200*60mm , A1=AC 110V , A2=AC 220V , H=High speed , S=Sleeve , B=Ball , L=Lead wire

FM 20060S/FM20060F Axial ac fan

sunflow®

交流风机

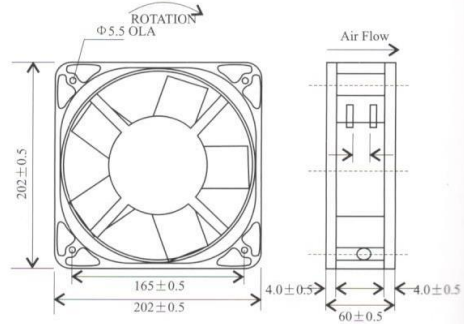

200 × 200 × 60mm(Square)

型号 Model	频率 Frequency Hz	电压 Voltage V	轴承 Bearing Type	电流 Current Amp	功率 Power W	转速 Speed Rpm	风量 Airflow Cfm	噪音 Noise dB(A)	重量 Weight Gram
FM20060A1HSL	50/60	110	Sleeve	0.80/0.78	65/63	2400	420/480	64/66	1700g
FM20060A1HBL	50/60	110	Ball	0.80/0.78	65/63	2400	420/480	64/66	
FM20060A2HSL	50/60	220	Sleeve	0.38/0.36	65/63	2400	420/480	64/66	
FM20060A2HBL	50/60	220	Ball	0.38/0.36	65/63	2400	420/480	64/66	

FM=Factory Model , 20060=200*200*60mm ,A1=AC 110V , A2=AC 220V , H=High speed , S=Sleeve , B=Ball , L=Lead wire

AXIAL AC FAN

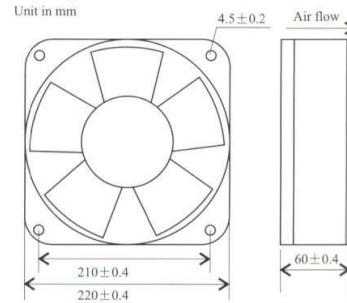

200 × 200 × 60mm(Round & Square)

型号 Model	频率 Frequency Hz	电压 Voltage V	轴承 Bearing Type	电流 Current Amp	功率 Power W	转速 Speed Rpm	风量 Airflow Cfm	噪音 Noise dB(A)	重量 Weight Gram
FM20060A1HSL	50/60	110	Sleeve	0.58/0.50	56/54	2100	170/180	64/66	1700g
FM20060A1HBL	50/60	110	Ball	0.58/0.50	56/54	2100	170/180	64/66	
FM20060A2HSL	50/60	220	Sleeve	0.31/0.30	56/54	2100	170/180	64/66	
FM20060A2HBL	50/60	220	Ball	0.31/0.30	56/54	2100	170/180	64/66	

FM=Factory Model , 20060=200*200*60mm ,A1=AC 110V , A2=AC 220V , H=High speed , S=Sleeve , B=Ball , L=Lead wire

FM 200FZY/FM22580

Axial ac fan



交流风机

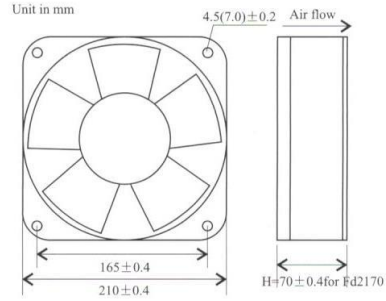

200FZY Series

型号 Model	频率 Frequency Hz	电压 Voltage V	轴承 Bearing Type	电流 Current Amp	功率 Power W	转速 Speed Rpm	风量 Airflow m ³ /min	噪音 Noise dB(A)	相数 Phase	电容 Capacitor μ F/V
200FZY2-D	50/60	220V	Ball	0.30	65	2500	13	70	1	1 μ F/500v
200FZY3-D	50/60	380V	Ball	0.15	65	2600	13	70	3	/
200FZY4-D	50/60	380V	Ball	0.16	65	2600	13	70	1	0.47 μ F/500v

AXIAL AC FAN

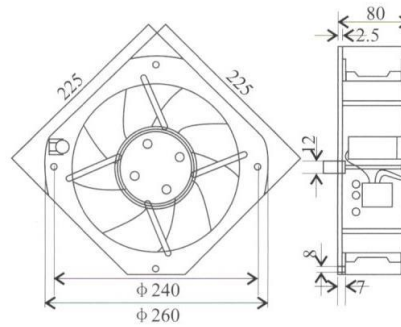

225x225x80mm(Square)

型号 Model	频率 Frequency Hz	电压 Voltage V	轴承 Bearing Type	电流 Current Amp	功率 Power W	转速 Speed Rpm	风量 Airflow m ³ /min	噪音 Noise dB(A)	相数 Phase	电容 Capacitor μ F/V
FM22580A1HB	50/60	110V	Ball	0.70	75	2600	17	160	1	5 μ F/250v
FM22580A2HB	50/60	220V	Ball	0.35	75	2600	17	160	1	2 μ F/250v
FM22580A3HB1	50/60	380V	Ball	0.25	75	2600	17	160	1	1.5 μ F/500v
FM22580A3HB	50/60	380V	Ball	0.20	75	2600	17	160	3	/

FM 4010/4020

Axial dc fan



直流风机

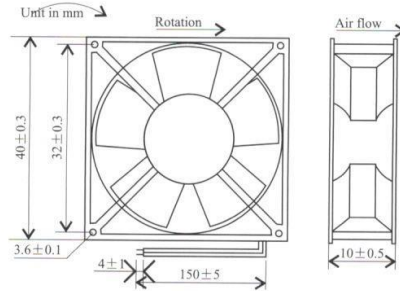
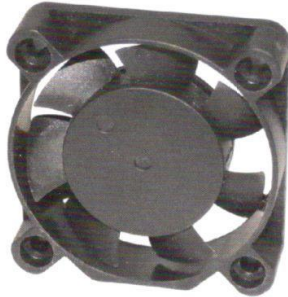

40 × 40 × 10mm

型号 Model	电压 Voltage V	轴承 Bearing Type	电流 Current Amp	功率 Power W	转速 Speed Rpm	风量 Airflow Cfm	噪音 Noise dB(A)	重量 Weight Gram
FM4010D05MSL	5	Sleeve	0.11	0.55	4800	5.70	20	16g
FM4010D05HSL	5	Sleeve	0.19	0.95	6000	6.70	25	
FM4010D12MSL	12	Sleeve	0.08	0.96	4800	5.70	20	
FM4010D12HSL	12	Sleeve	0.10	1.20	6000	6.70	25	
FM4010D24MSL	24	Sleeve	0.08	1.92	4800	5.70	20	
FM4010D24HSL	24	Sleeve	0.09	2.16	6000	6.70	25	

4010=40*40*10mm ,D05=5V, D12=12V,D24=24V, H=High speed ,M=Middle speed, S=Sleeve , L=Lead wire

AXIAL DC FAN

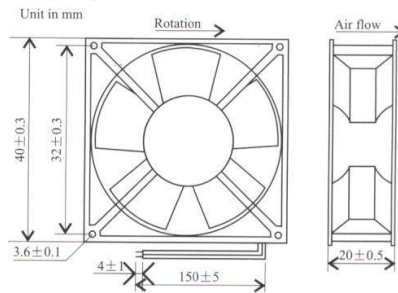

40 × 40 × 20mm

型号 Model	电压 Voltage V	轴承 Bearing Type	电流 Current Amp	功率 Power W	转速 Speed Rpm	风量 Airflow Cfm	噪音 Noise dB(A)	重量 Weight Gram
FM4020D05MSL	5	Sleeve	0.16	0.80	6500	8.10	27	28g
FM4020D05HSL	5	Sleeve	0.19	2.00	7500	9.20	31	
FM4020D12MSL	12	Sleeve	0.08	0.96	6900	8.50	28	
FM4020D12HSL	12	Sleeve	0.10	1.20	7800	10.10	31	
FM4020D24MSL	24	Sleeve	0.07	1.68	6800	8.50	28	
FM4020D24HSL	24	Sleeve	0.09	2.16	7800	10.10	31	

4020=40*40*20mm ,D05=5V,D12=12V,D24=24V, H=High speed ,M=Middle speed, S=Sleeve , L=Lead wire

FM 5010/5015

Axial dc fan



直流风机

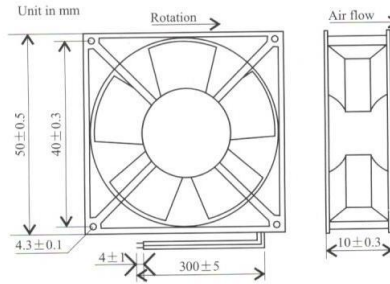

50 × 50 × 10mm

型号 Model	电压 Voltage V	轴承 Bearing Type	电流 Current Amp	功率 Power W	转速 Speed Rpm	风量 Airflow Cfm	噪音 Noise dB(A)	重量 Weight Gram
FM5010D05MSL	5	Sleeve	0.18	0.90	4300	10.50	24	20g
FM5010D05HSL	5	Sleeve	0.23	1.15	5000	11.20	26	
FM5010D12MSL	12	Sleeve	0.07	0.84	4300	10.50	24	
FM5010D12HSL	12	Sleeve	0.09	1.08	5000	11.20	26	
FM5010D24MSL	24	Sleeve	0.08	1.92	4300	10.50	24	
FM5010D24HSL	24	Sleeve	0.09	2.16	5000	11.20	26	

5010=50*50*10mm ,D05=5V,D12=12V,D24=24V, H=High speed ,M=Middle speed, S=Sleeve , L=Lead wire

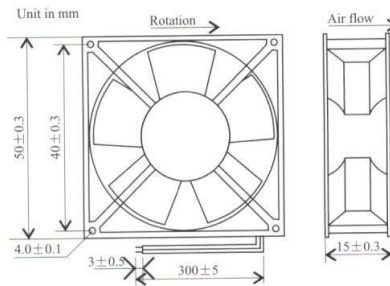

50 × 50 × 15mm

型号 Model	电压 Voltage V	轴承 Bearing Type	电流 Current Amp	功率 Power W	转速 Speed Rpm	风量 Airflow Cfm	噪音 Noise dB(A)	重量 Weight Gram
FM5015D05MSL	5	Sleeve	0.25	1.25	5000	14.55	33	28g
FM5015D05HSL	5	Sleeve	0.28	1.40	6000	16.22	36	
FM5015D12MSL	12	Sleeve	0.15	1.80	5000	14.55	33	
FM5015D12HSL	12	Sleeve	0.19	2.28	6000	16.22	36	
FM5015D24MSL	24	Sleeve	0.08	1.92	5000	14.55	33	
FM5015D24HSL	24	Sleeve	0.11	2.64	6000	16.22	36	

5015=50*50*15mm ,D05=5V,D12=12V,D24=24V, H=High speed ,M=Middle speed, S=Sleeve , L=Lead wire

AXIAL DC FAN

FM 6010/6015

Axial dc fan



直流风机

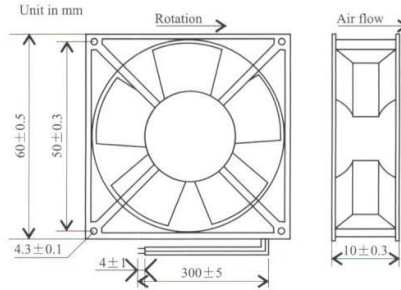

60 × 60 × 10mm

型号 Model	电压 Voltage V	轴承 Bearing Type	电流 Current Amp	功率 Power W	转速 Speed Rpm	风量 Airflow Cfm	噪音 Noise dB(A)	重量 Weight Gram
FM6010D05MSL	5	Sleeve	0.22	1.10	4000	17.03	32	23g
FM6010D05HSL	5	Sleeve	0.30	1.50	5000	20.02	36	
FM6010D12MSL	12	Sleeve	0.12	1.44	4000	17.03	32	
FM6010D12HSL	12	Sleeve	0.18	2.16	5000	20.02	36	
FM6010D24MSL	24	Sleeve	0.12	2.88	4000	18.22	32	
FM6010D24HSL	24	Sleeve	0.15	3.60	5000	20.02	36	

6010=60*60*10mm ,D05=5V,D12=12V,D24=24V, H=High speed ,M=Middle speed, S=Sleeve , L=Lead wire

AXIAL DC FAN

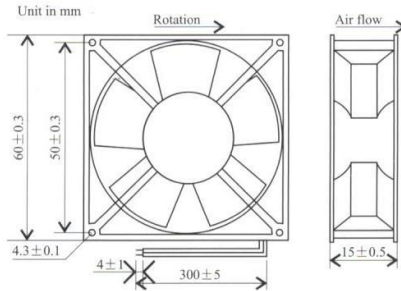

60 × 60 × 15mm

型号 Model	电压 Voltage V	轴承 Bearing Type	电流 Current Amp	功率 Power W	转速 Speed Rpm	风量 Airflow Cfm	噪音 Noise dB(A)	重量 Weight Gram
FM6015D05MSL	5	Sleeve	0.25	1.25	3900	14.20	28	30g
FM6015D05HSL	5	Sleeve	0.37	1.85	4500	16.60	32	
FM6015D12MSL	12	Sleeve	0.11	1.32	3900	14.20	28	
FM6015D12HSL	12	Sleeve	0.13	1.56	4500	16.60	32	
FM6015D24MSL	24	Sleeve	0.08	1.92	4200	15.50	28	
FM6015D24HSL	24	Sleeve	0.09	2.16	4500	16.20	32	

6015=60*60*15mm ,D05=5V,D12=12V,D24=24V, H=High speed ,M=Middle speed, S=Sleeve , L=Lead wire

FM 6020/6025

Axial dc fan



直流风机

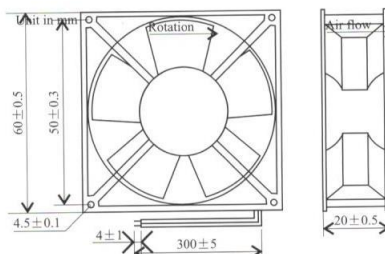

60 × 60 × 20mm

型号 Model	电压 Voltage V	轴承 Bearing Type	电流 Current Amp	功率 Power W	转速 Speed Rpm	风量 Airflow Cfm	噪音 Noise dB(A)	重量 Weight Gram
FM6020D05MSL	5	Sleeve	0.26	1.30	4500	16.50	29	45g
FM6020D05HSL	5	Sleeve	0.30	1.50	5000	17.20	32	
FM6020D12MSL	12	Sleeve	0.13	1.56	3900	14.50	29	
FM6020D12HSL	12	Sleeve	0.16	1.92	4500	16.40	32	
FM6020D24MSL	24	Sleeve	0.08	1.92	3900	14.50	29	
FM6020D24HSL	24	Sleeve	0.09	2.18	4500	16.40	32	

6020=60*60*20mm ,D05=5V,D12=12V,D24=24V, H=High speed ,M=Middle speed, S=Sleeve , L=Lead wire

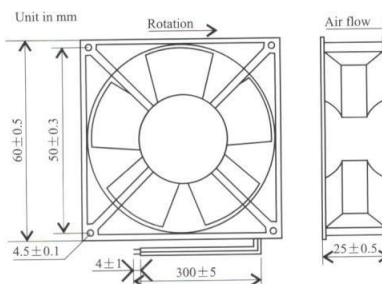

60 × 60 × 25mm

型号 Model	电压 Voltage V	轴承 Bearing Type	电流 Current Amp	功率 Power W	转速 Speed Rpm	风量 Airflow Cfm	噪音 Noise dB(A)	重量 Weight Gram
FM6025D05MSL	5	Sleeve	0.25	1.25	3400	17.80	25	62g
FM6025D05HSL	5	Sleeve	0.32	1.60	3900	22.30	29	
FM6025D12MSL	12	Sleeve	0.14	1.68	3500	18.00	25	
FM6025D12HSL	12	Sleeve	0.23	2.76	4500	23.20	29	
FM6025D24MSL	24	Sleeve	0.08	1.92	3500	18.60	25	
FM6025D24HSL	24	Sleeve	0.15	3.60	4500	23.20	29	

6025=60*60*25mm ,D05=5V,D12=12V,D24=24V, H=High speed ,M=Middle speed, S=Sleeve , L=Lead wire

AXIAL DC FAN

FM 7015/8025

Axial dc fan



直流风机

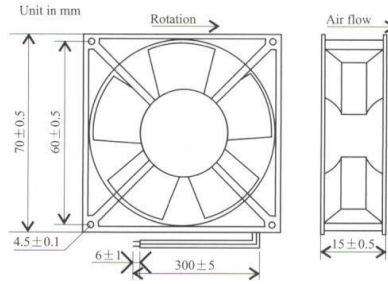

70 × 70 × 15mm

型号 Model	电压 Voltage V	轴承 Bearing Type	电流 Current Amp	功率 Power W	转速 Speed Rpm	风量 Airflow Cfm	噪音 Noise dB(A)	重量 Weight Gram
FM7015D05MSL	5	Sleeve	0.25	1.25	2400	22.40	25	65g
FM7015D05HSL	5	Sleeve	0.32	1.60	3000	27.80	28	
FM7015D12MSL	12	Sleeve	0.12	1.44	2400	22.40	25	
FM7015D12HSL	12	Sleeve	0.18	2.18	3200	28.50	28	
FM7015D24MSL	24	Sleeve	0.10	2.40	2400	22.40	25	
FM7015D24HSL	24	Sleeve	0.13	3.12	3200	28.50	28	

7015=70*70*15mm ,D05=5V,D12=12V,D24=24V, H=High speed ,M=Middle speed ,S=Sleeve , L=Lead wire

AXIAL DC FAN

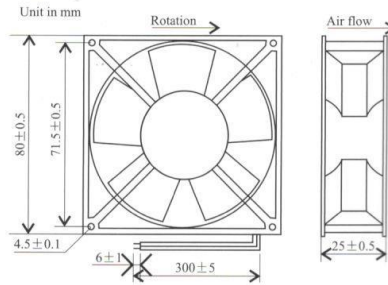

80 × 80 × 25mm

型号 Model	电压 Voltage V	轴承 Bearing Type	电流 Current Amp	功率 Power W	转速 Speed Rpm	风量 Airflow Cfm	噪音 Noise dB(A)	重量 Weight Gram
FM8025D05MSL	5	Sleeve	0.32	1.60	2500	32.90	30	80g
FM8025D05HSL	5	Sleeve	0.38	1.90	3000	38.60	36	
FM8025D12MSL	12	Sleeve	0.14	1.68	2600	32.90	30	
FM8025D12HSL	12	Sleeve	0.18	2.16	3000	38.60	36	
FM8025D24MSL	24	Sleeve	0.08	1.92	2600	32.90	30	
FM8025D24HSL	24	Sleeve	0.10	2.40	3000	38.60	36	

8025=80*80*25mm ,D05=5V,D12=12V,D24=24V, H=High speed ,M=Middle speed ,S=Sleeve , L=Lead wire

FM 9225/12025

Axial dc fan



直流风机

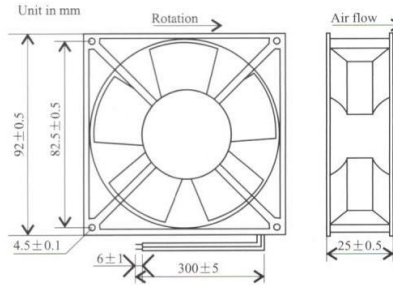

92 × 92 × 25mm

型号 Model	电压 Voltage V	轴承 Bearing Type	电流 Current Amp	功率 Power W	转速 Speed Rpm	风量 Airflow Cfm	噪音 Noise dB(A)	重量 Weight Gram
FM9225D05MSL	5	Sleeve	0.35	1.75	2500	36.00	30	103g
FM9225D05HSL	5	Sleeve	0.40	2.00	3000	45.00	32	
FM9225D12MSL	12	Sleeve	0.16	1.92	2500	36.00	30	
FM9225D12HSL	12	Sleeve	0.20	2.40	3000	45.00	32	
FM9225D24MSL	24	Sleeve	0.12	2.88	2500	36.00	30	
FM9225D24HSL	24	Sleeve	0.16	3.60	3000	45.00	32	

9225=92*92*25mm ,D05=5V,D12=12V,D24=24V, H=High speed ,M=Middle speed, S=Sleeve , L=Lead wire

AXIAL DC FAN

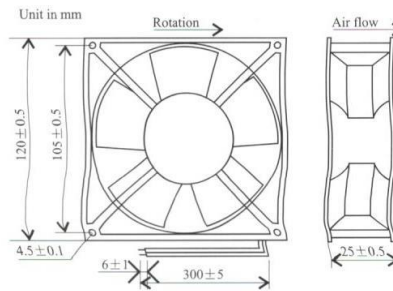

120 × 120 × 25mm

型号 Model	电压 Voltage V	轴承 Bearing Type	电流 Current Amp	功率 Power W	转速 Speed Rpm	风量 Airflow Cfm	噪音 Noise dB(A)	重量 Weight Gram
FM12025D12MSL	12	Sleeve	0.20	2.40	2200	74.20	35	164g
FM12025D12HSL	12	Sleeve	0.28	3.36	2400	83.00	39	
FM12025D24MSL	24	Sleeve	0.17	3.96	2200	74.20	35	
FM12025D24HSL	24	Sleeve	0.33	4.08	2400	83.00	39	

12025=120*120*25mm , D12=12V,D24=24V, H=High speed ,M=Middle speed, S=Sleeve , L=Lead wire

FM 12038/17250 Axial dc fan



直流风机

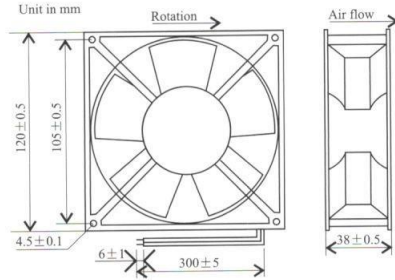

120 × 120 × 38mm

型号 Model	电压 Voltage V	轴承 Bearing Type	电流 Current Amp	功率 Power W	转速 Speed Rpm	风量 Airflow Cfm	噪音 Noise dB(A)	重量 Weight Gram
FM12038D12MSL	12	Sleeve	0.32	3.84	2300	85.00	36	250g
FM12038D12HSL	12	Sleeve	0.34	4.08	2500	95.00	40	
FM12038D24HSL	24	Sleeve	0.20	4.80	2500	95.00	40	
FM12038D48HSL	48	Sleeve	0.18	8.64	2500	95.00	40	
12038=120*120*38mm , D12=12V , D24=24V, H=High speed ,M=Middle speed, S=Sleeve , L=Lead wire								

AXIAL DC FAN

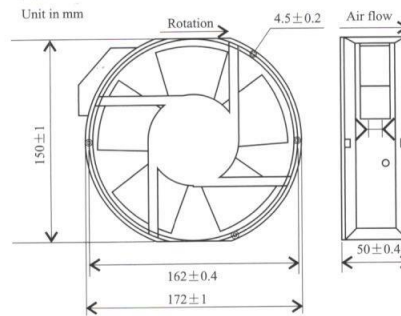



172 × 150 × 50mm

型号 Model	电压 Voltage V	轴承 Bearing Type	电流 Current Amp	功率 Power W	转速 Speed Rpm	风量 Airflow Cfm	噪音 Noise dB(A)	重量 Weight Gram
FM17250D12HBL	12	Ball	1.20	14.40	2300	155	47	800g
FM17250D24HBL	24	Ball	0.65	15.60	2400	160	47	
FM17250D48HBL	48	Ball	0.40	19.20	2400	160	47	
17250=172*150*50mm , D12=12V , D24=24V, D48=48V, H=High speed ,S=Sleeve , L=Lead wire								

FAN ACCESSORIES

风扇配件

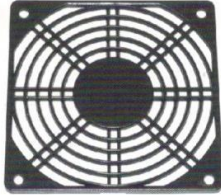

金属网罩	Metal Finger Guard	
	Model: FG-40, FG-50, FG-60, FG-70, FG-80, FG-92, FG-120, FG-145, FG-150, FG-200 Material 材料: Metal (Silver) 金属 Size 尺寸: from 40mm x 40mm to 200mm x 200mm Thickness 厚度: 5.5mm Be used for fans 适用风扇: from 40mm x 40mm to 200mm x 200mm	
塑料网罩	Plastic Finger Guard	
	FGP-80 Material 材料: Plastic 塑料 Thickness 厚度: 2.2mm	Size 尺寸: 80 x 80mm Applicable for fans 适用风扇: 8025,8038
	FGP-92 Material 材料: Plastic 塑料 Thickness 厚度: 2.2mm	Size 尺寸: 92 x 92mm Applicable for fans 适用风扇: 9225,9238
	FGP-120 Material 材料: Plastic 塑料 Thickness 厚度: 2.2mm	Size 尺寸: 120 x 120mm Applicable for fans 适用风扇: 12038,12025
过滤防尘网罩	Filter Finger Guard	
	FF-80(With Filter) Material 材料: Plastic 塑料 Thickness 厚度: 11mm	Size 尺寸: 80 x 80mm Applicable for fans 适用风扇: 8015,8020,8025,8038
	FF-92(With Filter) Material 材料: Plastic 塑料 Thickness 厚度: 11mm	Size 尺寸: 92 x 92mm Applicable for fans 适用风扇: 9225,9238
	FF-120(With Filter) Material 材料: Plastic 塑料 Thickness 厚度: 11mm	Size 尺寸: 120 x 120mm Applicable for fans 适用风扇: 12038,12025
过滤防尘网罩	Filter Finger Guard	
	FF-150(With Filter) Material 材料: Plastic 塑料 Thickness 厚度: 11mm	Size 尺寸: 150 x 150mm Applicable for fans 适用风扇: 12038,12025
	FF-205(With Filter) Material 材料: Plastic 塑料 Thickness 厚度: 11mm	Size 尺寸: 205 x 205mm Applicable for fans 适用风扇: 12025,12038,17250
	FF-256(With Filter) Material 材料: Plastic 塑料 Thickness 厚度: 11mm	Size 尺寸: 356 x 356mm Applicable for fans 适用风扇: 12038,12025,17250,22060

AXIAL DC FAN